

# UF Quick-Change U-Style Frame & Companion Insert Molds

## Frame

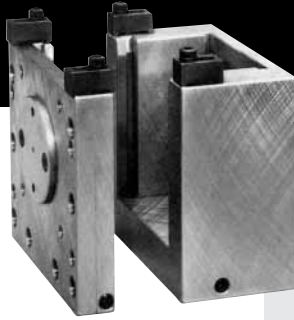

ITEM  
NO.

05/05 UF 321

**NOTE:** Use of spacers allows this frame to accept MUD 3.25 x 3.15 insert molds (see page OP 146).

### UF 321 Frame Upper – Side View

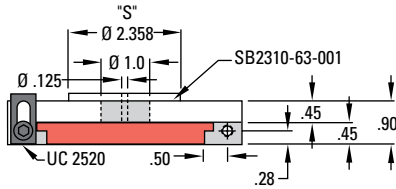

**NOTE:** Sprue bushing supplied flat with .125 small diameter orifice standard.

### UF 321 Frame Upper – Top View

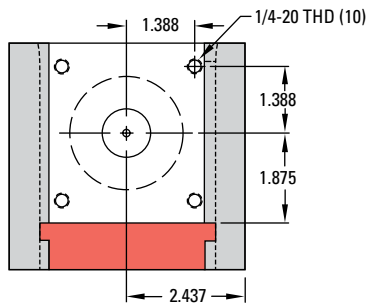

### UF 321 Frame Lower – Side View

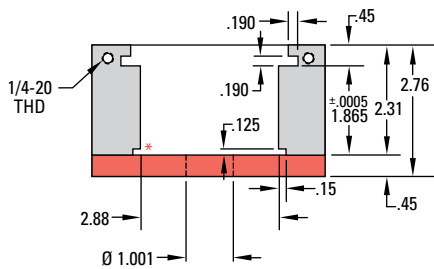

\* 0 degree - 15 minute taper slot to accommodate sleeve ejection retainer plate. Slot tapers from .125 to .109 in 3.750 length.

### UF 321 Frame Lower – Top View

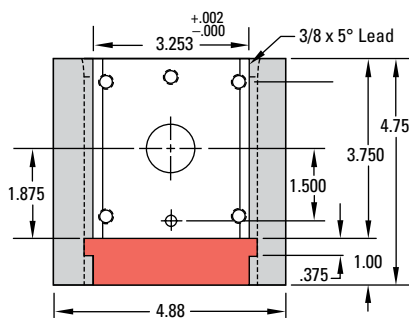

## Companion Interchangeable Insert Molds

- 1 Frame clamps at this end of insert mold and ejector plates are flush with this end of insert.
- 2 Support post not supplied. Grind +.001 to +.002 higher than height of ejection (see page C 131).
- 3 Thicker plate optional.

### Standard Solid: 3.25 x 3.75

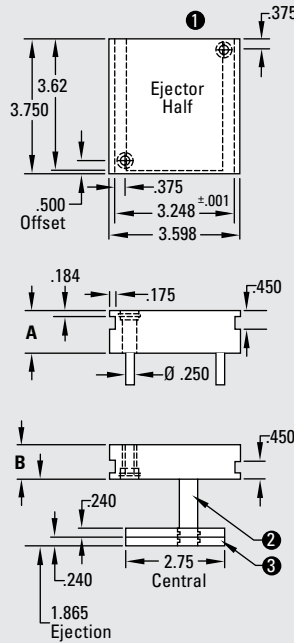

### Standard Laminated: 3.25 x 3.75

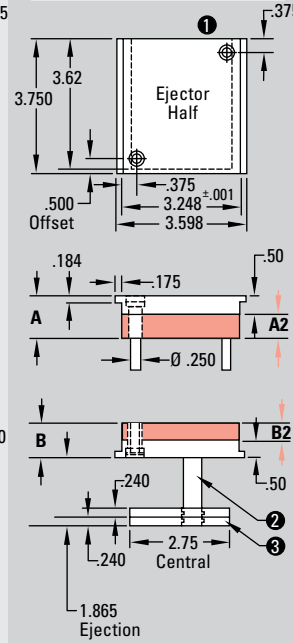

### T-Style Laminated: 4.0 x 4.7

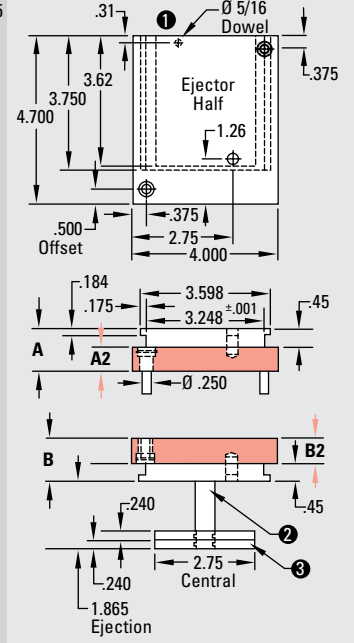

### Standard Solid Construction

ITEM NO.	A	B
05/05 SSU 221	1.377	1.377
05/05 SSU 222	1.877	1.877

### Standard Laminated Construction

ITEM NO.	A	A2	B2	B
05/05 SLU 281	1.377	0.877	0.877	1.377
05/05 SLU 282	1.877	1.377	1.377	1.877

### T-Style Laminated Construction

ITEM NO.	A	A2	B2	B
05/05 TLU 201	1.450	1.000	1.000	1.450
05/05 TLU 202	1.950	1.500	1.500	1.950

Ordering information for frame and companion insert molds can be found in the front of this section.



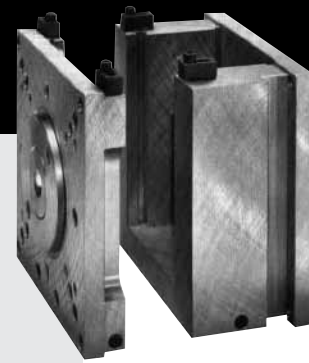

**Frame**

**ITEM NO.**  
07/07 UF 321

**Companion Interchangeable Insert Molds**

- 1 Frame clamps at this end of insert mold and ejector plates are flush with this end of insert.
- 2 Support post not supplied. Grind +.001 to +.002 higher than height of ejection (see page C 131).
- 3 Thicker plate optional.

**Standard Solid:**  
4.5 x 6.25

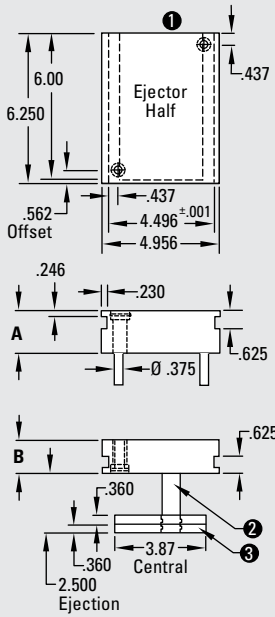

**Standard Laminated:**  
4.5 x 6.25

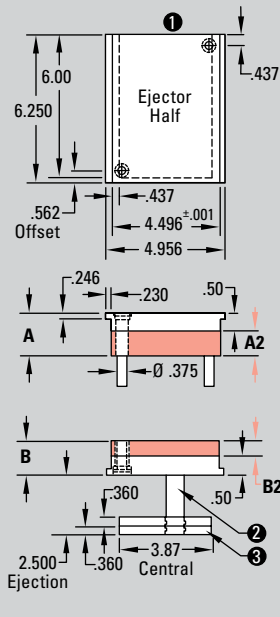

**T-Style Solid or Laminated:**  
6.0 x 7.25

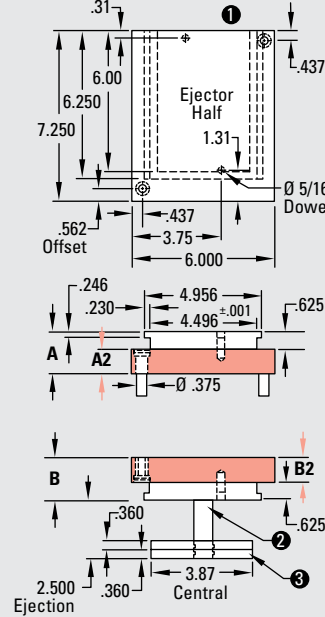

**UF 321 Frame Upper – Side View**

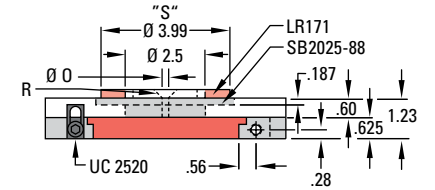

**UF 321 Frame Upper – Top View**

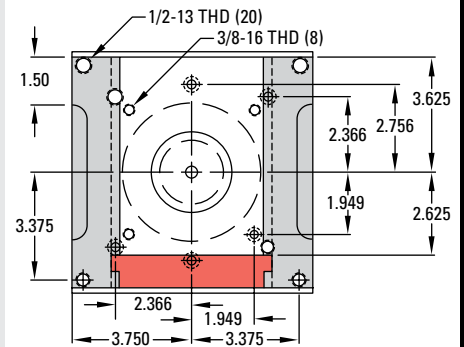

**UF 321 Frame Lower – Side View**

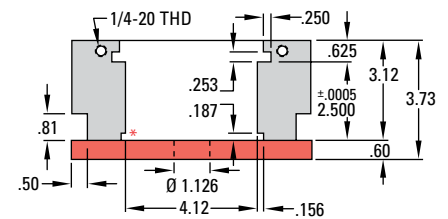

**UF 321 Frame Lower – Top View**

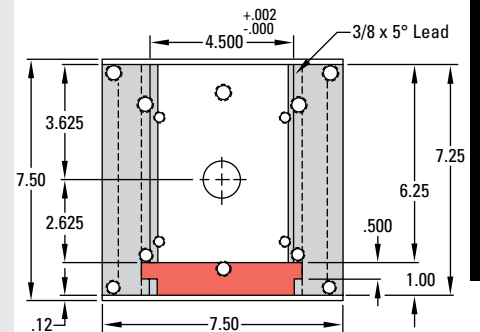

\* 0 degree - 15 minute taper slot to accommodate sleeve ejection retainer plate. Slot tapers from .187 to .160 in 6.250 length.

**Standard Solid Construction**

ITEM NO.	A	B
07/07 SSU 221	1.377	1.377
07/07 SSU 222	1.377	1.877
07/07 SSU 223	1.877	1.377
07/07 SSU 224	1.877	1.877

**Standard Laminated Construction**

ITEM NO.	A	A2	B2	B
07/07 SLU 281	1.377	0.877	0.877	1.377
07/07 SLU 282	1.377	0.877	1.377	1.877
07/07 SLU 283	1.877	1.377	0.877	1.377
07/07 SLU 284	1.877	1.377	1.377	1.877

**T-Style Solid Construction**

ITEM NO.	A	A2	B2	B
07/07 TSU 241	1.625	1.000	1.000	1.625
07/07 TSU 242	1.875	1.250	1.250	1.875

**T-Style Laminated Construction**

ITEM NO.	A	A2	B2	B
07/07 TLU 201	1.625	1.000	1.000	1.625
07/07 TLU 202	1.875	1.250	1.250	1.875

Ordering information for frame and companion insert molds can be found in the front of this section.

MUD Quick-Change Mold Frames & Inserts for U-Style | 07/07 UF 321



# UF Quick-Change U-Style Frame & Companion Insert Molds

## Frame

ITEM  
NO.

08/09 UF 321

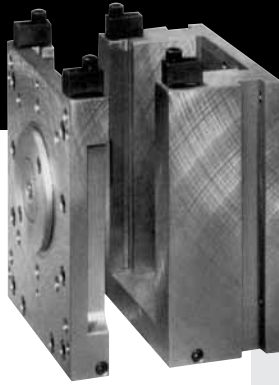

## Companion Interchangeable Insert Molds

- 1 Frame clamps at this end of insert mold and ejector plates are flush with this end of insert.
- 2 Support post not supplied. Grind  $+0.001$  to  $+0.002$  higher than height of ejection (see page C 131).
- 3 Thicker plate optional.

UF 321 Frame Upper – Side View

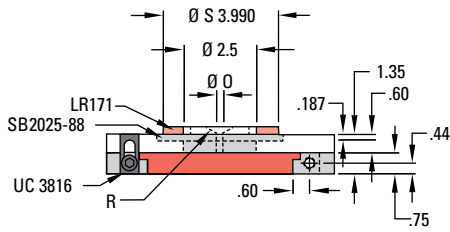

UF 321 Frame Upper – Top View

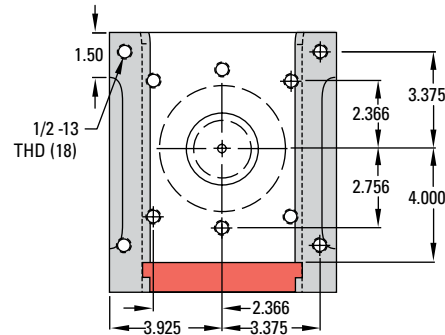

UF 321 Frame Lower – Side View

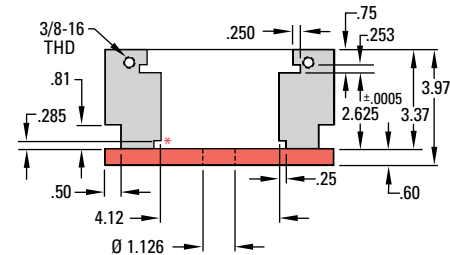

\* 0 degree - 15 minute taper slot to accommodate sleeve ejection retainer plate. Slot tapers from .285 to .250 in 8.000 length.

UF 321 Frame Lower – Top View

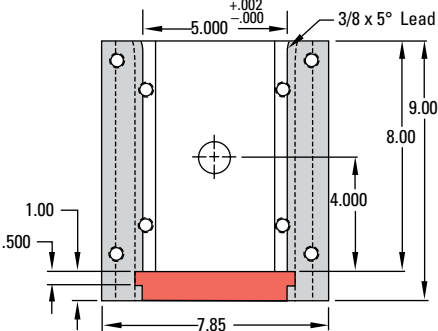

Standard Solid:  
5.0 x 8.0

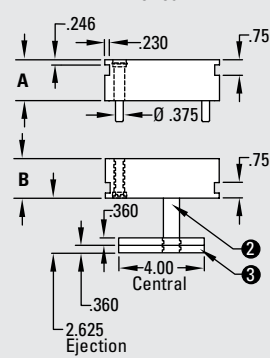
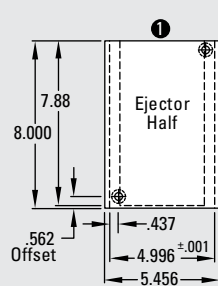

Standard Laminated:  
5.0 x 8.0

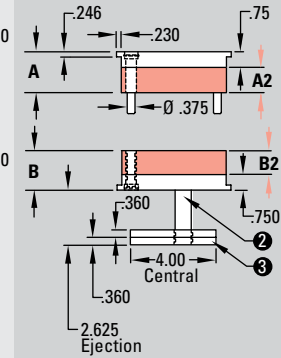
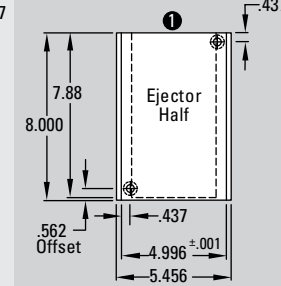

T-Style Solid or  
Laminated: 7.85 x 9.0

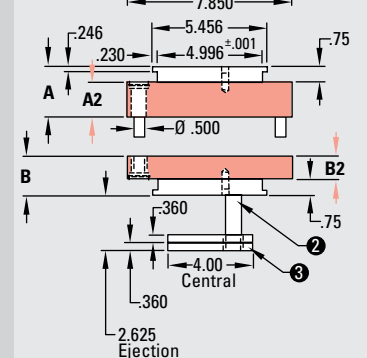
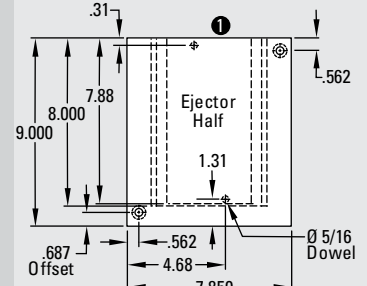

### Standard Solid Construction

ITEM NO.	A	B
08/09 SSU 221	1.377	1.377
08/09 SSU 222	1.377	1.877
08/09 SSU 223	1.877	1.377
08/09 SSU 224	1.877	1.877
08/09 SSU 225	1.877	2.377
08/09 SSU 226	2.377	1.877
08/09 SSU 227	2.377	2.377
08/09 SSU 228	2.377	2.877
08/09 SSU 229	2.877	2.377
08/09 SSU 230	2.877	2.877

### T-Style Solid Construction

ITEM NO.	A	A2	B2	B
08/09 TSU 241	1.750	1.000	1.000	1.750
08/09 TSU 242	1.750	1.000	1.500	2.250
08/09 TSU 243	2.000	1.250	1.250	2.000
08/09 TSU 244	2.250	1.500	1.000	1.750
08/09 TSU 245	2.250	1.500	1.500	2.250
08/09 TSU 246	2.625	1.875	1.875	2.625

### Standard Laminated Construction

ITEM NO.	A	A2	B2	B
08/09 SLU 281	1.377	0.627	0.627	1.377
08/09 SLU 282	1.377	0.627	1.127	1.877
08/09 SLU 283	1.877	1.127	0.627	1.377
08/09 SLU 284	1.877	1.127	1.127	1.877
08/09 SLU 285	1.877	1.127	1.627	2.377
08/09 SLU 286	2.377	1.627	1.127	1.877
08/09 SLU 287	2.377	1.627	1.627	2.377
08/09 SLU 288	2.377	1.627	2.127	2.877
08/09 SLU 289	2.877	2.127	1.627	2.377
08/09 SLU 290	2.877	2.127	2.127	2.877

### T-Style Laminated Construction

ITEM NO.	A	A2	B2	B
08/09 TLU 201	1.750	1.000	1.000	1.750
08/09 TLU 202	1.750	1.000	1.500	2.250
08/09 TLU 203	2.000	1.250	1.250	2.000
08/09 TLU 204	2.250	1.500	1.000	1.750
08/09 TLU 205	2.250	1.500	1.500	2.250
08/09 TLU 206	2.625	1.875	1.875	2.625

### Solid Construction Aluminum Companion Insert Molds

ITEM NO.	A	B
08/09 ALU 208	1.875	1.875
08/09 ALU 210	2.375	1.875

NOTE: "A" & "B" dimensions are supplied  $\pm 0.001$  on all aluminum companion insert molds.

Ordering information for frame and companion insert molds can be found in the front of this section.



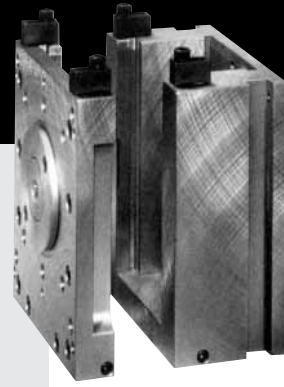

**Frame**

**ITEM NO.**  
08/10 UF 321

**Companion Interchangeable Insert Molds**

- 1 Frame clamps at this end of insert mold and ejector plates are flush with this end of insert.
- 2 Support post not supplied. Grind +.001 to +.002 higher than height of ejection (see page C 131).
- 3 Thicker plate optional.

**Standard Solid:**  
5.0 x 9.0

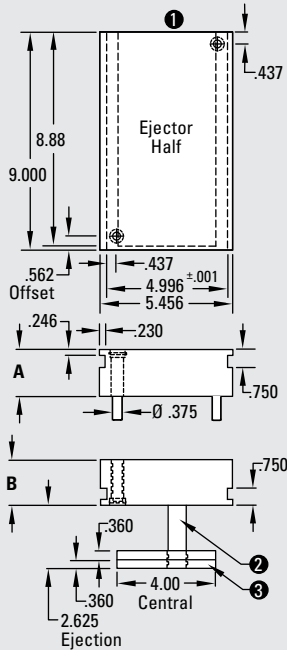

**Standard Laminated:**  
5.0 x 9.0

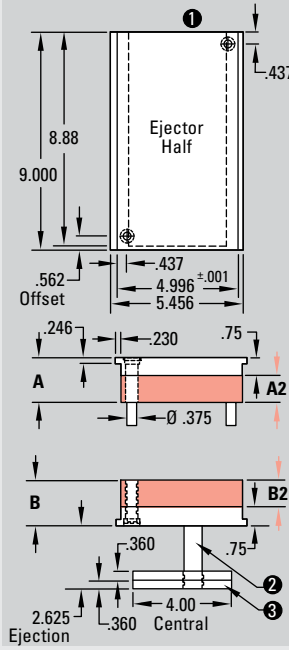

**T-Style Solid or Laminated:**  
7.85 x 9.0

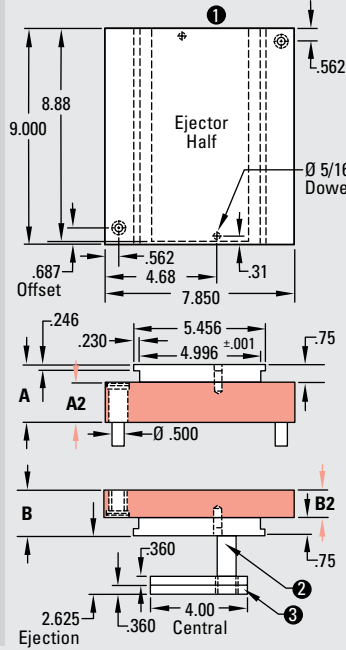

**UF 321 Frame Upper – Side View**

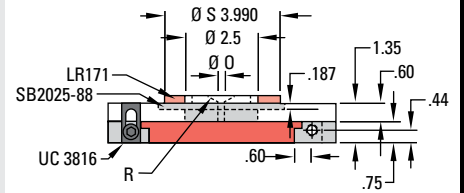

**UF 321 Frame Upper – Top View**

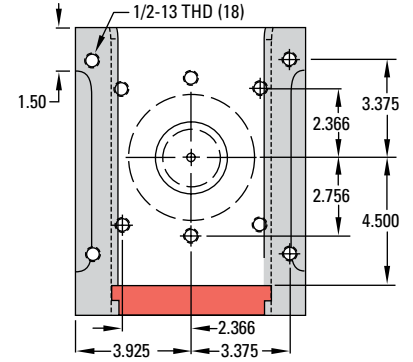

**UF 321 Frame Lower – Side View**

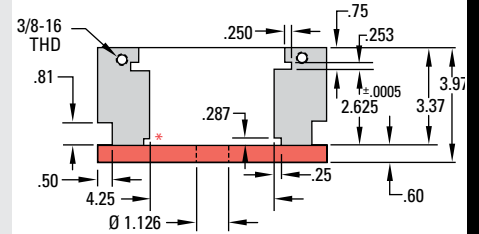

\* 0 degree - 15 minute taper slot to accommodate sleeve ejection retainer plate. Slot tapers from .287 to .248 in 9.000 length.

**UF 321 Frame Lower – Top View**

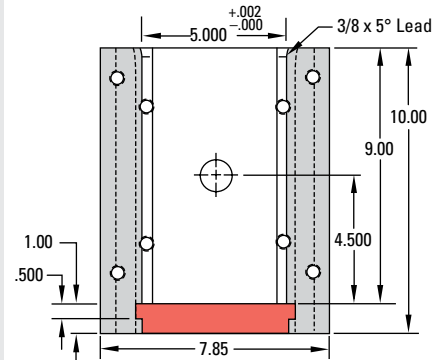

**Standard Solid Construction**

ITEM NO.	A	B
08/10 SSU 221	1.377	1.377
08/10 SSU 222	1.377	1.877
08/10 SSU 223	1.877	1.377
08/10 SSU 224	1.877	1.877
08/10 SSU 225	1.877	2.377
08/10 SSU 226	2.377	1.877
08/10 SSU 227	2.377	2.377
08/10 SSU 228	2.377	2.877
08/10 SSU 229	2.877	2.377
08/10 SSU 230	2.877	2.877

**T-Style Solid Construction**

ITEM NO.	A	A2	B2	B
08/10 TSU 241	1.750	1.000	1.000	1.750
08/10 TSU 242	1.750	1.000	1.500	2.250
08/10 TSU 243	2.000	1.250	1.250	2.000
08/10 TSU 244	2.250	1.500	1.000	1.750
08/10 TSU 245	2.250	1.500	1.500	2.250
08/10 TSU 246	2.625	1.875	1.875	2.625

**Standard Laminated Construction**

ITEM NO.	A	A2	B2	B
08/10 SLU 281	1.377	0.627	0.627	1.377
08/10 SLU 282	1.377	0.627	1.127	1.877
08/10 SLU 283	1.877	1.127	0.627	1.377
08/10 SLU 284	1.877	1.127	1.127	1.877
08/10 SLU 285	1.877	1.127	1.627	2.377
08/10 SLU 286	2.377	1.627	1.127	1.877
08/10 SLU 287	2.377	1.627	1.627	2.377
08/10 SLU 288	2.377	1.627	2.127	2.877
08/10 SLU 289	2.877	2.127	1.627	2.377
08/10 SLU 290	2.877	2.127	2.127	2.877

**T-Style Laminated Construction**

ITEM NO.	A	A2	B2	B
08/10 TLU 201	1.750	1.000	1.000	1.750
08/10 TLU 202	1.750	1.000	1.500	2.250
08/10 TLU 203	2.000	1.250	1.250	2.000
08/10 TLU 204	2.250	1.500	1.000	1.750
08/10 TLU 205	2.250	1.500	1.500	2.250
08/10 TLU 206	2.625	1.875	1.875	2.625

Ordering information for frame and companion insert molds can be found in the front of this section.



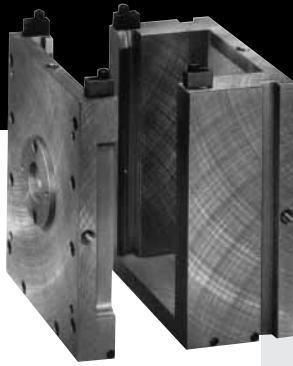

# UF Quick-Change U-Style Frame & Companion Insert Molds

## Frame

ITEM NO.

94/90 UF 321

NOTE: For extended clamp bar option, see page OP 144.

### UF 321 Frame Upper – Side View

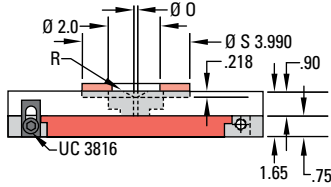

### UF 321 Frame Upper – Top View

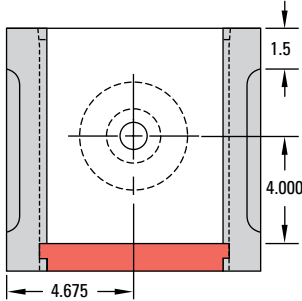

### UF 321 Frame Lower – Side View

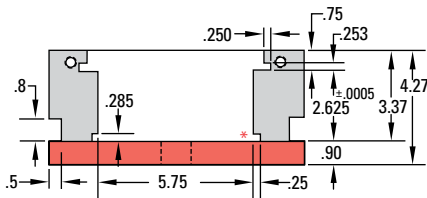

\* 0 degree - 15 minute taper slot to accommodate sleeve ejection retainer plate. Slot tapers from .285 to .250 in 8.000 length.

### UF 321 Frame Lower – Top View

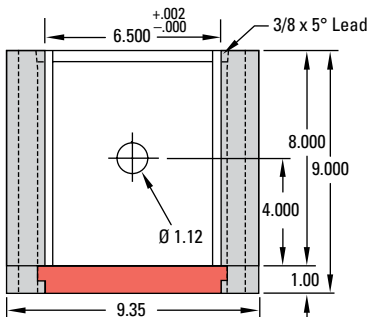

## Companion Interchangeable Insert Molds

- 1 Frame clamps at this end of insert mold and ejector plates are flush with this end of insert.
- 2 Support post not supplied. Grind +.001 to +.002 higher than height of ejection (see page C 131).
- 3 Thicker plate optional.

### Standard Solid: 6.5 x 8.0

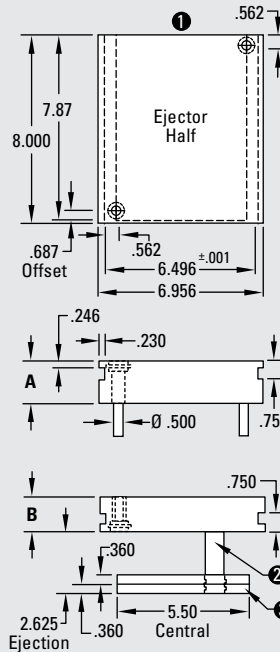

### Standard Laminated: 6.5 x 8.0

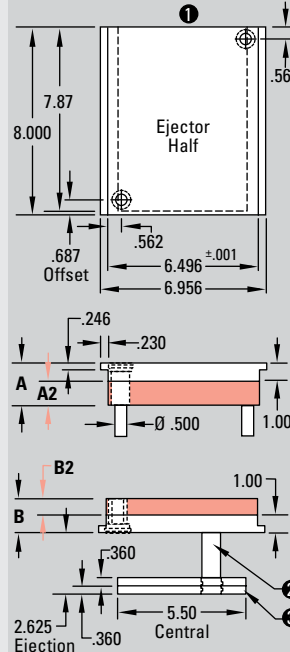

### T-Style Solid or Laminated: 8.4 x 8.0

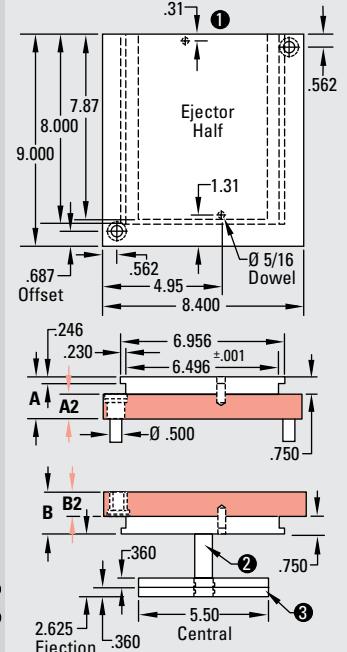

### Standard Solid Construction

ITEM NO.	A	B
84/90 SSU 221	1.377	1.377
84/90 SSU 222	1.377	1.877
84/90 SSU 223	1.877	1.377
84/90 SSU 224	1.877	1.877
84/90 SSU 225	1.877	2.377
84/90 SSU 226	2.377	1.877
84/90 SSU 227	2.377	2.377
84/90 SSU 228	2.377	2.877
84/90 SSU 229	2.877	2.377
84/90 SSU 230	2.877	2.877

### T-Style Solid Construction

ITEM NO.	A	A2	B2	B
84/90 TSU 241	1.500	0.750	1.250	2.000
84/90 TSU 242	1.750	1.000	1.000	1.750
84/90 TSU 243	1.750	1.000	1.500	2.250
84/90 TSU 244	2.000	1.250	1.250	2.000
84/90 TSU 245	2.250	1.500	1.000	1.750
84/90 TSU 246	2.250	1.500	1.500	2.250
84/90 TSU 247	2.625	1.875	1.875	2.625

### Standard Laminated Construction

ITEM NO.	A	A2	B2	B
84/90 SLU 281	1.877	0.877	0.877	1.877
84/90 SLU 282	1.877	0.877	1.377	2.377
84/90 SLU 283	2.377	1.377	0.877	1.877
84/90 SLU 284	2.377	1.377	1.377	2.377
84/90 SLU 285	2.377	1.377	1.877	2.877
84/90 SLU 286	2.877	1.877	1.377	2.377
84/90 SLU 287	2.877	1.877	1.877	2.877

### T-Style Laminated Construction

ITEM NO.	A	A2	B2	B
84/90 TLU 201	1.500	0.750	1.250	2.000
84/90 TLU 202	1.750	1.000	1.000	1.750
84/90 TLU 203	1.750	1.000	1.500	2.250
84/90 TLU 204	2.000	1.250	1.250	2.000
84/90 TLU 205	2.250	1.500	1.000	1.750
84/90 TLU 206	2.250	1.500	1.500	2.250
84/90 TLU 207	2.625	1.875	1.875	2.625

### Solid Construction Aluminum Companion Insert Molds

ITEM NO.	A	B
84/90 ALU 210	2.375	1.875

Ordering information for frame and companion insert molds can be found in the front of this section.

NOTE: "A" & "B" dimensions are supplied ±.001 on all aluminum companion insert molds.





**Frame**

**ITEM NO.**  
84/90 UF 321

**Companion Interchangeable Insert Molds**

- 1 Frame clamps at this end of insert mold and ejector plates are flush with this end of insert.
- 2 Support post not supplied. Grind +.001 to +.002 higher than height of ejection (see page C 131).
- 3 Thicker plate optional.

**Standard Solid:  
6.5 x 8.0**

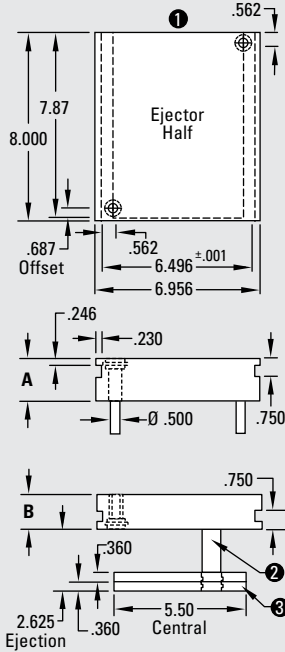

**Standard Laminated:  
6.5 x 8.0**

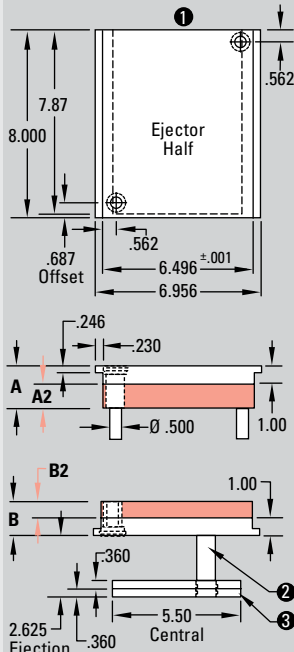

**T-Style Solid or  
Laminated: 8.4 x 9.0**

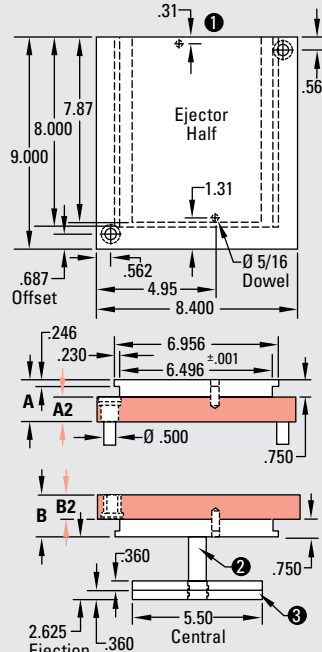

**UF 321 Frame Upper – Side View**

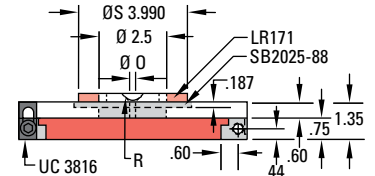

**UF 321 Frame Upper – Top View**

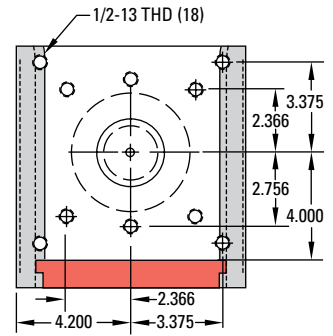

**UF 321 Frame Lower – Side View**

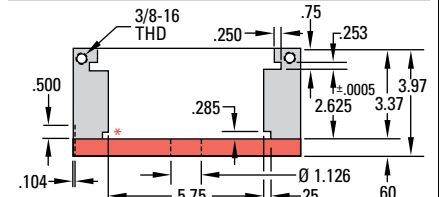

\*0 degree - 15 minute taper slot to accommodate sleeve ejection retainer plate. Slot tapers from .285 to .250 in 8.000 length.

**UF 321 Frame Lower – Top View**

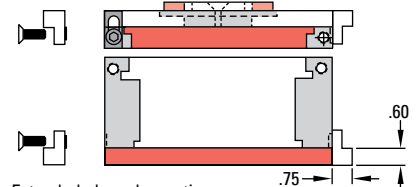
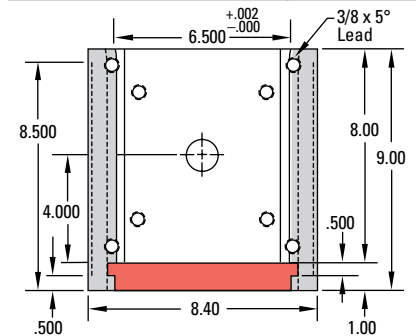

Extended clamp bar option:  
Set of four (4) bars required.  
See page OP 144.

**Standard Solid Construction**

ITEM NO.	A	B
84/90 SSU 221	1.377	1.377
84/90 SSU 222	1.377	1.877
84/90 SSU 223	1.877	1.377
84/90 SSU 224	1.877	1.877
84/90 SSU 225	1.877	2.377
84/90 SSU 226	2.377	1.877
84/90 SSU 227	2.377	2.377
84/90 SSU 228	2.377	2.877
84/90 SSU 229	2.877	2.377
84/90 SSU 230	2.877	2.877

**T-Style Solid Construction**

ITEM NO.	A	A2	B2	B
84/90 TSU 241	1.500	0.750	1.250	2.000
84/90 TSU 242	1.750	1.000	1.000	1.750
84/90 TSU 243	1.750	1.000	1.500	2.250
84/90 TSU 244	2.000	1.250	1.250	2.000
84/90 TSU 245	2.250	1.500	1.000	1.750
84/90 TSU 246	2.250	1.500	1.500	2.250
84/90 TSU 247	2.625	1.875	1.875	2.625

**T-Style Laminated Construction**

ITEM NO.	A	A2	B2	B
84/90 TLU 201	1.500	0.750	1.250	2.000
84/90 TLU 202	1.750	1.000	1.000	1.750
84/90 TLU 203	1.750	1.000	1.500	2.250
84/90 TLU 204	2.000	1.250	1.250	2.000
84/90 TLU 205	2.250	1.500	1.000	1.750
84/90 TLU 206	2.250	1.500	1.500	2.250
84/90 TLU 207	2.625	1.875	1.875	2.625

**Solid Construction  
Aluminum Companion Insert Molds**

ITEM NO.	A	B
84/90 ALU 210	2.375	1.875

NOTE: "A" & "B" dimensions are supplied ±.001 on all aluminum companion insert molds.

**Standard Laminated Construction**

ITEM NO.	A	A2	B2	B
84/90 SLU 281	1.877	0.877	0.877	1.877
84/90 SLU 282	1.877	0.877	1.377	2.377
84/90 SLU 283	2.377	1.377	0.877	1.877
84/90 SLU 284	2.377	1.377	1.377	2.377
84/90 SLU 285	2.377	1.377	1.877	2.877
84/90 SLU 286	2.877	1.877	1.377	2.377
84/90 SLU 287	2.877	1.877	1.877	2.877

Ordering information for frame and companion insert molds can be found in the front of this section.

MUD Quick-Change Mold Frames & Inserts for U-Style | 84/90 UF 321



# UF Quick-Change U-Style Shuttle Frame & Companion Insert Molds

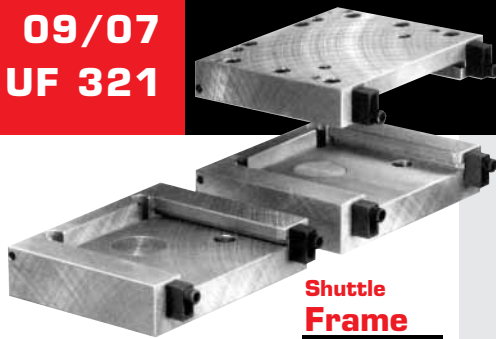

**Shuttle Frame**

ITEM NO.  
09/07 UF 321

### UF 321 Frame Upper – Side View

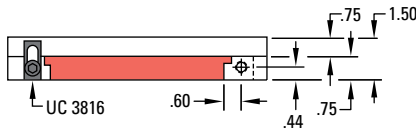

### UF 321 Frame Upper – Top View

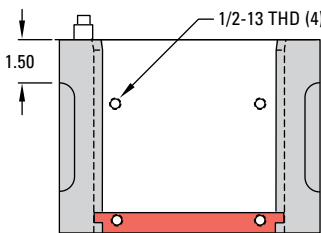

Cavity half, one (1) required.

### UF 321 Frame Lower – Side View

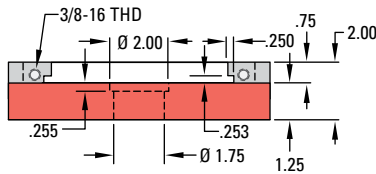

### UF 321 Frame Lower – Top View

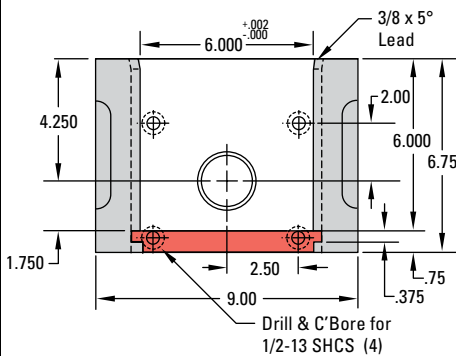

Ejector half, two (2) required.

### KO Rod Spacer

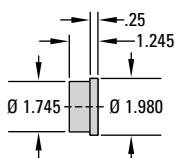

Two (2) required.

Knockout rod spacer standard as shown.

**NOTE:** Insert molds can be ordered with two (2) "B" halves by noting "S" after catalog code number.

## Companion Interchangeable Insert Molds

1 Frame clamps at this end of insert mold.

Standard Solid:  
6.0 x 6.75

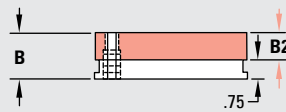
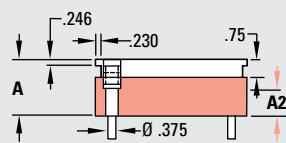
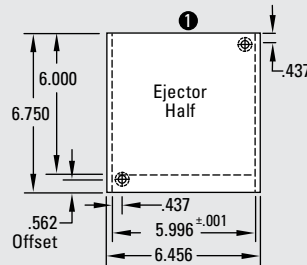

T-Style Solid or Laminated: 9.0 x 6.75

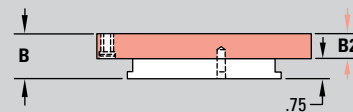
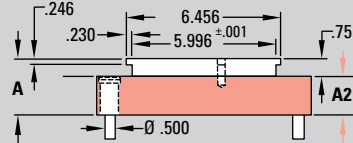
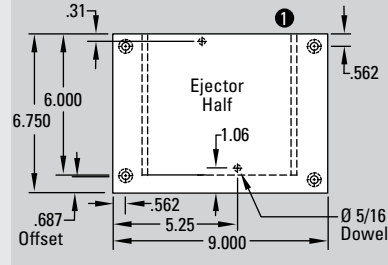

Optional

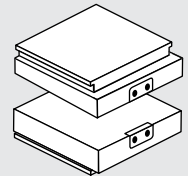

Hardened runner pads available (quotation on request).

### Standard Solid Construction

ITEM NO.	A	A2	B2	B
09/07 SSU 221	2.250	1.500	1.500	2.250

### T-Style Solid Construction

ITEM NO.	A	A2	B2	B
09/07 TSU 241	2.250	1.500	1.500	2.250

### T-Style Laminated Construction

ITEM NO.	A	A2	B2	B
09/07 TLU 201	2.250	1.500	1.500	2.250

Ordering information for frame and companion insert molds can be found in the front of this section.

**NOTE:** When ejection is required, pockets can be machined in ejector half of insert mold and ejector plates installed.

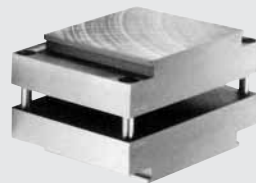
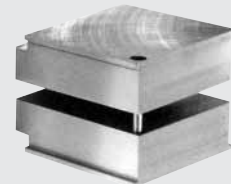

# EB Quick-Change U-Style Shuttle Frame & Companion Insert Molds

09/07  
EB 321

## Companion Interchangeable Insert Molds

- ① Frame clamps at this end of insert mold and ejector plates are flush with this end of insert.
- ② Support post not supplied. Grind +.001 to +.002 higher than height of ejection (see page C 131).
- ③ Thicker plate optional.

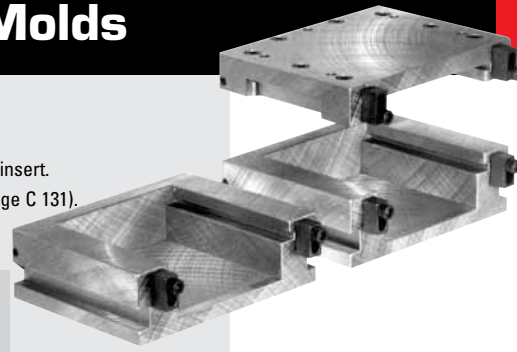

Shuttle  
Frame

ITEM  
NO.  
09/07 EB 321

Standard Solid:  
6.0 x 6.75

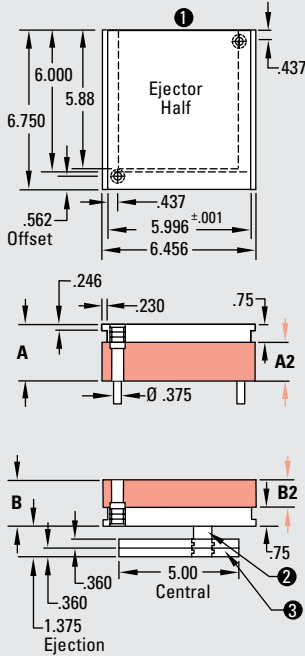

T-Style Solid or  
Laminated: 9.0 x 6.75

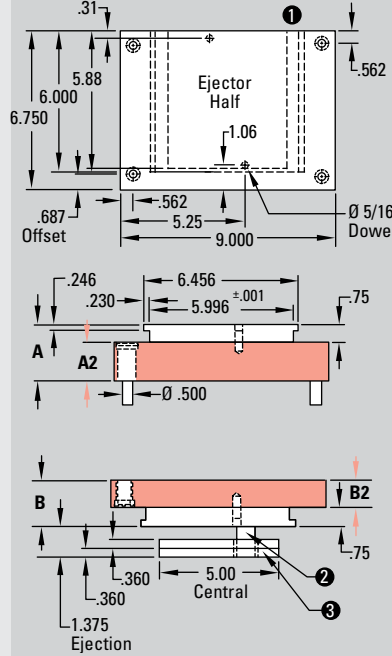

Optional

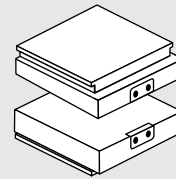

Hardened runner pads available (quotation on request).

### EB 321 Frame Upper – Side View

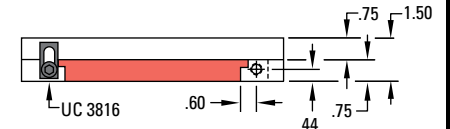

### EB 321 Frame Upper – Top View

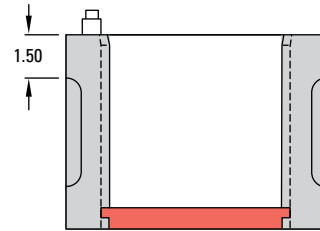

Cavity half, one (1) required.

### EB 321 Frame Lower – Side View

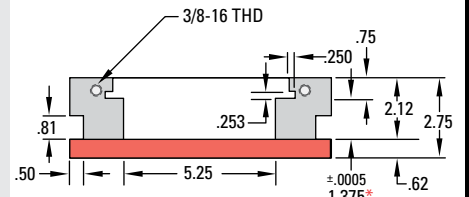

\* Height of ejection can be modified to suit nozzle height of machine (quotation on request).

### EB 321 Frame Lower – Top View

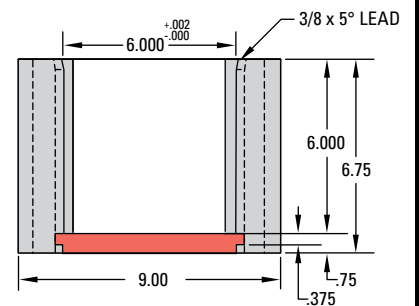

Ejector half, two (2) required.

**NOTE:** Insert molds can be ordered with two (2) "B" halves by noting "S" after catalog code number.

**NOTE:** Knockout hole locations per customer specifications (if required).

### Standard Solid Construction

ITEM NO.	A	A2	B2	B
09/07 SSE 221	2.250	1.500	1.500	2.250

### T-Style Solid Construction

ITEM NO.	A	A2	B2	B
09/07 TSE 241	2.250	1.500	1.500	2.250

### T-Style Laminated Construction

ITEM NO.	A	A2	B2	B
09/07 TLE 201	2.250	1.500	1.500	2.250

Ordering information for frame and companion insert molds can be found in the front of this section.

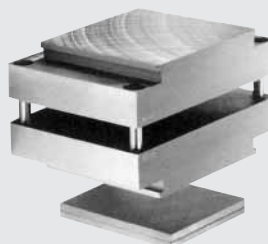
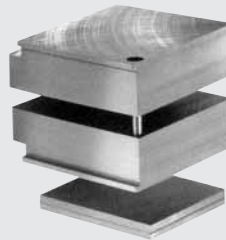

MUD Quick-Change Mold Frames & Inserts for U-Style | 09/07 EB 321





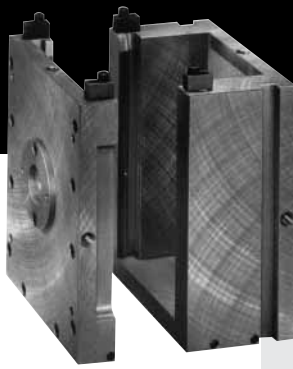

# UF Quick-Change U-Style Frame & Companion Insert Molds

## Frame

ITEM NO.

10/12 UF 321

UF 321 Frame Upper – Side View

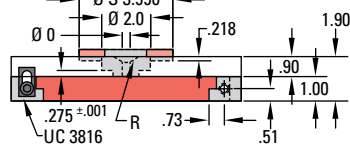

UF 321 Frame Upper – Top View

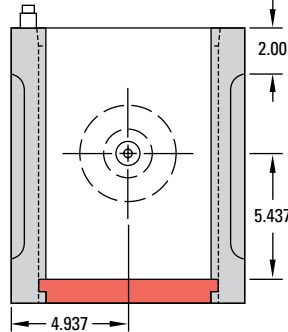

UF 321 Frame Lower – Side View

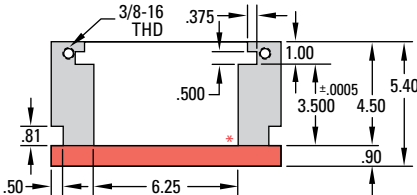

\*Taper slot to accommodate sleeve ejection optional (quotation on request).

UF 321 Frame Lower – Top View

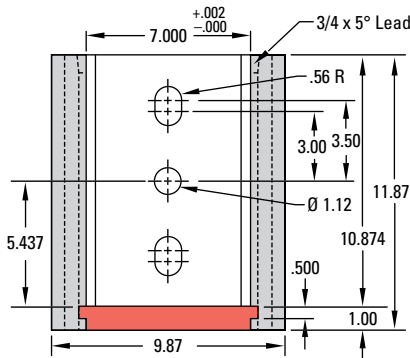

Frame supplied with or without sprue bushing

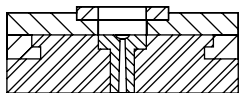

## Companion Interchangeable Insert Molds

- 1 Frame clamps at this end of insert mold and ejector plates are flush with this end of insert.
- 2 Support post not supplied. Grind +.001 to +.002 higher than height of ejection (see page C 131).
- 3 Thicker plate optional (quotation on request).
- 4 3/4 x 5° lead this end.

Standard Solid:  
7.0 x 10.9

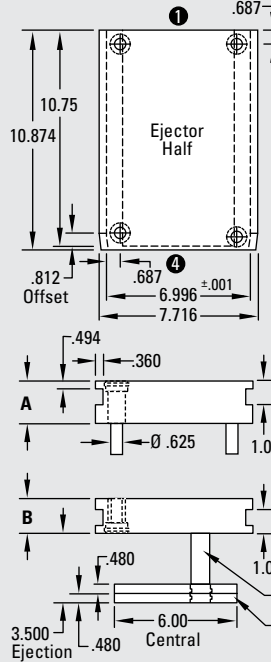

Standard Laminated:  
7.0 x 10.9

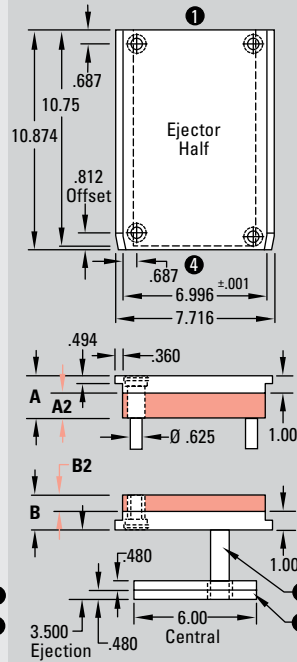

T-Style Laminated:  
9.9 x 10.9

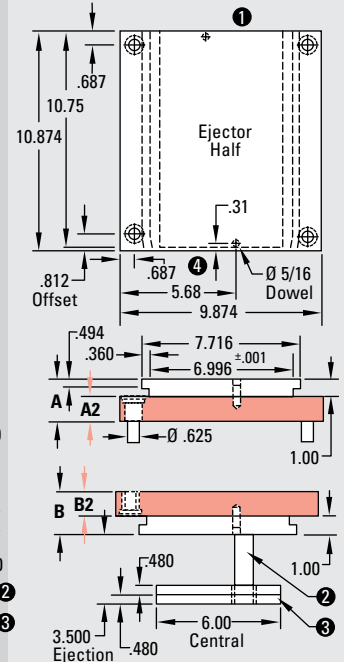

### Standard Solid Construction

ITEM NO.	A	B
10/12 SSU 221	1.377	1.377
10/12 SSU 222	1.377	1.877
10/12 SSU 223	1.877	1.377
10/12 SSU 224	1.877	1.877
10/12 SSU 225	1.877	2.377
10/12 SSU 226	2.377	1.877
10/12 SSU 227	2.377	2.377
10/12 SSU 228	2.377	2.877
10/12 SSU 229	2.877	2.377
10/12 SSU 230	2.877	2.877

### T-Style Laminated Construction

ITEM NO.	A	A2	B2	B
10/12 TLU 201	1.877	0.877	0.877	1.877
10/12 TLU 202	1.877	0.877	1.377	2.377
10/12 TLU 203	2.377	1.377	0.877	1.877
10/12 TLU 204	2.377	1.377	1.377	2.377
10/12 TLU 205	2.377	1.377	1.877	2.877
10/12 TLU 206	2.877	1.877	1.377	2.377
10/12 TLU 207	2.877	1.877	1.877	2.877
10/12 TLU 208	2.877	1.877	2.377	3.377
10/12 TLU 209	3.377	2.377	1.877	2.877
10/12 TLU 210	3.377	2.377	2.377	3.377

### Standard Laminated Construction

ITEM NO.	A	A2	B2	B
10/12 SLU 281	1.877	0.877	0.877	1.877
10/12 SLU 282	1.877	0.877	1.377	2.377
10/12 SLU 283	1.877	0.877	1.877	2.877
10/12 SLU 284	2.377	1.377	0.877	1.877
10/12 SLU 285	2.377	1.377	1.377	2.377
10/12 SLU 286	2.377	1.377	1.877	2.877
10/12 SLU 287	2.877	1.877	0.877	1.877
10/12 SLU 288	2.877	1.877	1.377	2.377
10/12 SLU 289	2.877	1.877	1.877	2.877

Ordering information for frame and companion insert molds can be found in the front of this section.



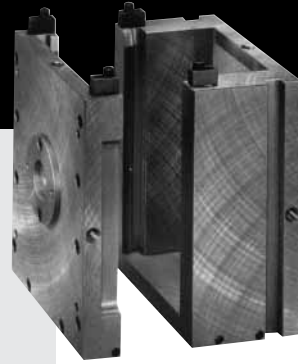

**Frame**

**ITEM NO.**  
10/14 UF 321

**Companion Interchangeable Insert Molds**

- 1 Frame clamps at this end of insert mold and ejector plates are flush with this end of insert.
- 2 Support post not supplied. Grind +.001 to +.002 higher than height of ejection (see page C 131).
- 3 Thicker plate optional (quotation on request).
- 4 3/4 x 5° lead this end.

**Standard Solid:**  
7.0 x 12.9

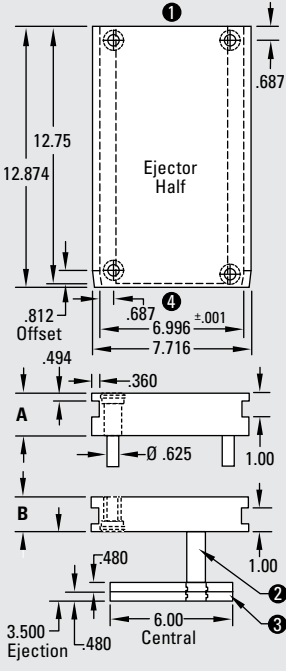

**Standard Laminated:**  
7.0 x 12.9

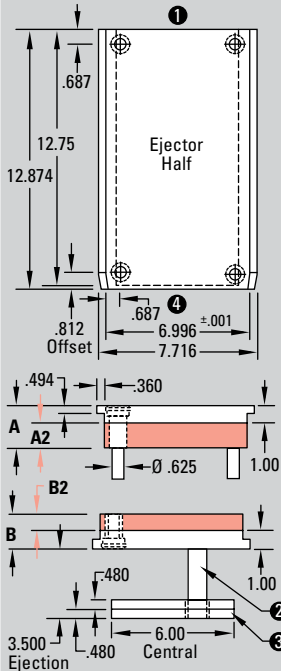

**T-Style Laminated:**  
9.9 x 12.9

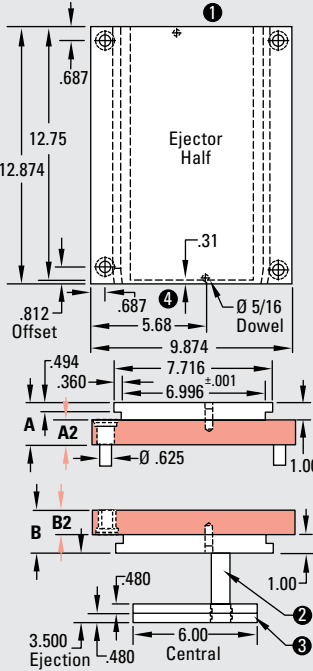

**UF 321 Frame Upper – Side View**

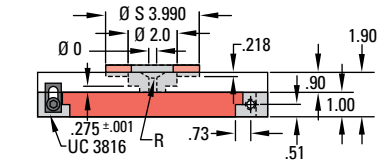

**UF 321 Frame Upper – Top View**

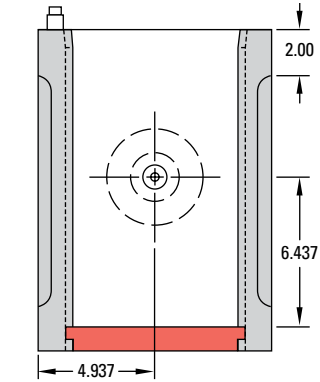

**UF 321 Frame Lower – Side View**

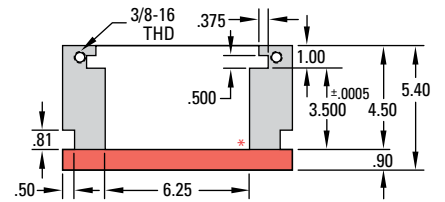

\* Taper slot to accommodate sleeve ejection optional (quotation on request).

**UF 321 Frame Lower – Top View**

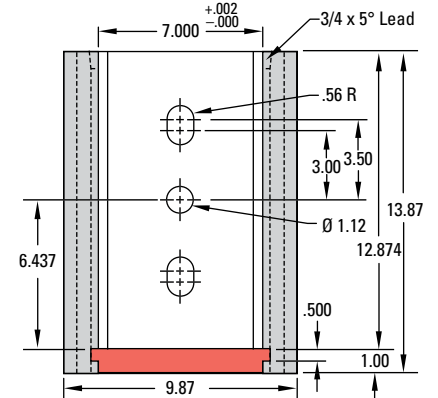

Frame supplied with or without sprue bushing

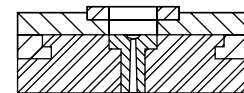

**Standard Solid Construction**

ITEM NO.	A	B
10/14 SSS 221	1.377	1.377
10/14 SSS 222	1.377	1.877
10/14 SSS 223	1.877	1.377
10/14 SSS 224	1.877	1.877
10/14 SSS 225	1.877	2.377
10/14 SSS 226	2.377	1.877
10/14 SSS 227	2.377	2.377
10/14 SSS 228	2.377	2.877
10/14 SSS 229	2.877	2.377
10/14 SSS 230	2.877	2.877

**T-Style Laminated Construction**

ITEM NO.	A	A2	B2	B
10/14 TLU 201	1.877	0.877	0.877	1.877
10/14 TLU 202	1.877	0.877	1.377	2.377
10/14 TLU 203	2.377	1.377	0.877	1.877
10/14 TLU 204	2.377	1.377	1.377	2.377
10/14 TLU 205	2.377	1.377	1.877	2.877
10/14 TLU 206	2.877	1.877	1.377	2.377
10/14 TLU 207	2.877	1.877	1.877	2.877
10/14 TLU 208	2.877	1.877	2.377	3.377
10/14 TLU 209	3.377	2.377	1.877	2.877
10/14 TLU 210	3.377	2.377	2.377	3.377

**Standard Laminated Construction**

ITEM NO.	A	A2	B2	B
10/14 SLU 281	1.877	0.877	0.877	1.877
10/14 SLU 282	1.877	0.877	1.377	2.377
10/14 SLU 283	1.877	0.877	1.877	2.877
10/14 SLU 284	2.377	1.377	0.877	1.877
10/14 SLU 285	2.377	1.377	1.377	2.377
10/14 SLU 286	2.377	1.377	1.877	2.877
10/14 SLU 287	2.877	1.877	0.877	1.877
10/14 SLU 288	2.877	1.877	1.377	2.377
10/14 SLU 289	2.877	1.877	1.877	2.877

Ordering information for frame and companion insert molds can be found in the front of this section.

MUD Quick-Change Mold Frames & Inserts for U-Style | 10/14 UF 321

